

# The George Whitefield ROCK

George Whitefield  
UMC

Volume 1, Issue 38  
July 2001

## FROM THE PASTOR

As I write this, the federal government for the second time in two weeks has executed a prisoner. The most noteworthy, of course, was Timothy McVeigh. No matter where you stand on the issue of capital punishment, this particular execution has caused many of us to give it some more serious thought. A poll taken in April by USA Today showed that 81% of Americans wanted McVeigh to be executed – and 28% of that support was from people who are normally against the death penalty. While I am steadfastly against capital punishment, I must admit that this case caused me to examine my position. In the end I hold to my understanding that it's God's business and not humans' to take a life, even when the person in question has played God in a sense and taken so many innocent lives. God is the final judge of the human heart and of human behavior. Belief in a God of justice helps me to leave McVeigh in God's hands.

Our United Methodist Social Principles have this to say about the issue of capital punishment: "... the mis treatment or torture of persons by governments for any purpose violates Christian teaching and must be condemned and/or opposed by Christians and churches wherever and whenever it occurs. For the same reason, **we oppose capital punishment and urge its elimination from all criminal codes.**"

For his final words, McVeigh chose to quote the last two lines of the poem "Invictus," which is Latin for "unconquered." These lines read: "I am the master of my fate: I am the captain of my soul." The whole poem, written by a 19<sup>th</sup> century British poet named William Ernest Henley, goes like this:

Out of the night that covers me,  
Black as the Pit from pole to pole,  
I thank whatever gods may be  
For my unconquerable soul.

In the fell clutch of circumstance  
I have not winced nor cried aloud,  
Under the bludgeonings of chance  
My head is bloody, but unbowed.

Beyond this place of wrath and tears  
Looms but the horror of the shade,  
And yet the menace of the years  
Finds, and shall find me, unafraid.

It matters not how strait the gate,  
How charged with punishments the scroll,  
I am the master of my fate:  
I am the captain of my soul.

When the poet Henley wrote these words, he wasn't thinking of setting his own standard of morality. He was giving voice to his attitude toward the hurts and setbacks of life. At the age of 12 he had developed tubercular arthritis, and his left foot was amputated in his teens. He had other health problems later on, and actually wrote this poem while in the hospital, too sick to work. For Henley, "Invictus" was an expression of courage in the face of life's difficulties, not a license to kill.

Right up until the end, McVeigh sought to be the master of his fate. In a letter written just a day before his death, he wrote that if it turned out that there was an afterlife, he would "improvise, adapt, and overcome." He may have a surprise waiting for him. Once we are at the judgment seat of God, none of us is any longer the master of our fate nor the captain of our soul. So we might as well get busy learning how to turn our lives over to God now, before it's too late.

Peace,  
Pastor Mary Jane

## Inside this issue:

<i>The Church and You</i>	2
<i>Coffee Hour</i>	2
<i>Calendar</i>	3
<i>Children's Sunday</i>	4
<i>The Church and The Community</i>	4
<i>Kid Corner</i>	5
<i>Readings Anniversaries Birthdays</i>	6
<i>Sponsors</i>	7

## The Church and You

### 2001 ANNUAL CONFERENCE HIGHLIGHTS

Pastor Mary Jane and Marion Hunt, Lay Member of Annual Conference, attended the New England Annual Conference at Gordon College in Wenham, MA on June 6-9. Here are some of the actions taken by the Annual Conference:

- ?????voted to hire a full-time Director of Youth Ministries to work with churches to develop youth ministries;
- ?????voted to engage in a formal act of repentance for racism at the 2002 Annual Conference, to be preceded by each church in the Conference conducting a study group using the book Steps Toward Wholeness: Learning and Repentance sometime in the next 12 months;
- ?????voted to discontinue the Jesse Lee Builders Fund;
- ?????voted to establish a covenant relationship with La Iglesia de Cristo en Nicaragua (The Church of Christ in Nicaragua) – the former Southern New England Conference has had a covenant with La Iglesia de Cristo for a number of years;
- ?????voted to approve legislation concerning Retiree Health Benefits (for the complete details, see the Conference Booklet available from Pastor Mary Jane or Marion Hunt);
- ?????voted that each church sometime in the following year observe “Vocational Sunday” which will help identify people who may be called into the ordained ministry, as well as lift up the call of every Christian to service for the sake of the gospel of Jesus Christ;
- ?????passed a number of Constitutional Amendments brought forth for Annual Conference approval from the General Conference held last year.

### WORSHIP COMMITTEE SEEKS COMMENTS

The Worship Committee voted in June to try a slightly different style of worship during the summer months, beginning on June 17<sup>th</sup>. The revised worship service will focus more on praise and prayer, with praise music to begin the service, and an expanded prayer time where people can share their concerns with the congregation. There will also be a “moment for mission” at the time of the offering, during which one of the missions of the United Methodist Church, or a possible new mission for our church, will be highlighted. There will be a brief questionnaire in the bulletin each Sunday so that people can give their feedback to the Worship Committee.



The people walking  
in darkness have  
seen a great light ....

Isaiah 9:2

### Coffee Host notice:

To make it easier for our Sunday Coffee Hosts, the nurture committee is making some changes in coffee hour: We will serve crackers and cheese and Munchkins (Donut Holes). The doughnuts will be paid for with money out of the donation dish but the hosts will be responsible for picking them up and supplying the crackers and cheese. Coffee, punch and creamer will be supplied. The children will be seated at their own special table.



Dot Bailey has taken over as chairperson of the Nurture Committee as of June 1st.

### COFFEE HOSTS

**July** 1st - Rev. Mary-Jane Ropp  
8th - Judith Bartlett  
15th - Mae Chicoine  
22nd - Al Varnum  
29th - April Learned

# July 2001

S	M	T	W	T	F	S
1	2	3	4	5	6	7
8	9	10	11	12	13	14
15	16	17	18	19	20	21
22	23	24	25	26	27	28
29	30	31				

S	M	T	W	T	F	S
			1	2	3	4
5	6	7	8	9	10	11
12	13	14	15	16	17	18
19	20	21	22	23	24	25
26	27	28	29	30	31	

## July Calendar of Events

- ????Monday, July 9 – Staff/Parish Relations Committee at parsonage, 7 p.m.
- ????Saturday, July 14 – Smorgasbord Supper at church, 6 p.m.
- ? Monday, July 16-Sunday, July 22 – Pastor on Vacation.
- ? Sunday, July 22 – Paul Chicoine preaching
- ????Monday, July 23 – Mission & Outreach Committee at church, 7 p.m.
- ????Wednesday, July 25 – Nurture Committee at parsonage, 9 a.m.
- ????Saturday, July 28 – United Methodist Women’s yard sale at church
- ????Sunday, July 29 – Church picnic and “dessert box social” at parsonage right after church
- ????Monday, July 30 – Wings & Hands craft group at church, 7 p.m.

## CALENDAR – REGULARLY SCHEDULED

- ????Bible study on the Book of Acts -Tuesdays at 10:00 a.m. at the home of Annalee Collins
- ????Prayer Group - Wednesdays at 2:15 p.m. at the parsonage
- ????Lectionary Bible study – Thursdays at 3:00 p.m. at the parsonage
- ????Pastor’s day off – Friday

## Children's Sunday



## The Church and The Community

### TAG SALE JULY 28

The UMW is planning a Food Sale and Tag Sale for July 28 at the church starting at 9AM. All U.M.W. are asked to donate at least two articles of food for the food sale and all church members are invited to bring tag sale items. The Tag Sale items may be left at the church (in Fellowship Hall) after the July 14th Supper, on Sundays. If you cannot take things in on Sundays, please call Annalee Collins at 867-7678 to arrange a time to drop them off. No clothing and no large appliances please.

### VACATION BIBLE SCHOOL AT FIRST CONGREGA- TIONAL CHURCH

This year's ecumenical VBS will be held from Monday, July 30<sup>th</sup> through Friday, August 3<sup>d</sup> from 9:00 a.m. to 12:15 p.m. at First Congregational Church on the Common in West Brookfield. The theme is "Polar Expedition: It's Cool to Love Jesus!" Children from pre-school through age 12 are invited. To pre-register, call Terry Hall at (508) 867-4462 or Pastor Mary Jane at (508) 867-3667. You may also register at the church on July 30<sup>th</sup>.

### ART LESSONS FOR CHILDREN

Two of our talented members, Judy Bartlett and Dell Marona, will be offering art lessons to area children during a week in the summer (dates to be announced). This is part of a continuing effort on the part of the Task Force on Ministry to Children and Families to reach out to the children in our communities with activities to enrich their lives. "Stay tuned" for the dates. This will be announced in local newspapers as well as in church on Sunday.

*If you love God most, you'll love others more*  
—Ray Hamilton

*Life is a grindstone: whether it grinds you down or polishes you up depends on what you're made of*  
.—Jacob M. Braude

Play this game outdoors with your friends!

# "In Paul's Footsteps"



1. Choose one person to be Paul.
2. Paul stands facing a tree or wall so the other players can't be seen.
3. The other players stand at a distance behind a line.
4. Paul says, "GO!" and the others try to sneak up and tap Paul.
5. As the players are moving toward Paul, Paul turns around and players must "freeze" in place. Anyone who moves must go back to the starting line.
6. Paul faces tree or wall again and the players continue to sneak up.
7. The first to tap Paul without getting caught wins and gets to be the next Paul.

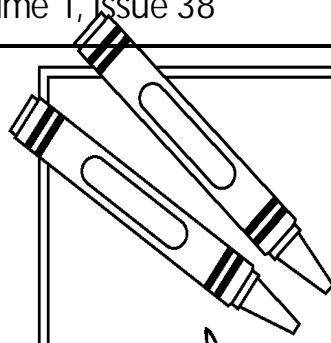
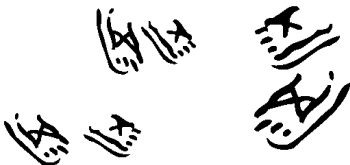

# Just for KIDS



## Vacation and Travel Time



Most people in the world today can move from one place to another easily. We can hop in the car, catch a bus, ride a bike or fly in a plane!

Fill in the missing parts of the words in this story. The missing parts are in the list below. Read the story.

In Bi\_\_\_\_\_mes tra\_\_\_\_\_ was diff\_\_\_\_\_ and \_\_\_\_\_ow. A full day's \_\_\_\_\_ney was \_\_\_\_\_nty miles. The \_\_\_\_\_ual way to \_\_\_\_\_vel was by \_\_\_\_\_king. \_\_\_\_\_keys were some\_\_\_\_\_ used. Ox c\_\_\_\_\_ car\_\_\_\_\_ hea\_\_\_\_\_ads. Ca\_\_\_\_\_ were used for \_\_\_\_\_ade cara\_\_\_\_\_. \_\_\_\_\_oss the \_\_\_\_\_ert. The mili\_\_\_\_\_, \_\_\_\_\_thy \_\_\_\_\_ple and ro\_\_\_\_\_. \_\_\_\_\_sengers used ho\_\_\_\_\_ and \_\_\_\_\_lots. Bo\_\_\_\_\_ were used once in a while.

\_\_\_\_\_ble ti\_\_\_\_\_vel \_\_\_\_\_icult sl\_\_\_\_\_jour\_\_\_\_\_twe\_\_\_\_\_us\_\_\_\_\_tra\_\_\_\_\_wal\_\_\_\_\_Don\_\_\_\_\_times \_\_\_\_\_arts \_\_\_\_\_ried \_\_\_\_\_vy lo\_\_\_\_\_rts tr\_\_\_\_\_vans acr\_\_\_\_\_des\_\_\_\_\_tary weal\_\_\_\_\_peo\_\_\_\_\_yal pas\_\_\_\_\_rses char\_\_\_\_\_ats

Answer: In Bible times travel was difficult and slow. A full days journey was twenty miles. The usual way to travel was by walking. Donkeys were sometimes used. Ox carts carried heavy loads. Carts were used for trade caravans across the desert. The military, wealthy people and royal passengers used horses and chariots. Boats were used once in a while.

**Scripture Readings: Notice**

Each month I will publish the readers for each weeks scripture lessons. It is requested that you read from the Lectern Bible. If you can not be in church on the week that you are scheduled to read, please arrange for someone else to read in your place or contact Paul Chicoine or Rev. Mary Jane. Pastor Mary Jane is willing to give tips/lessons to anyone desiring them. Also if you are interesting in being included in the readers list please notify Paul Chicoine at 436-7744.

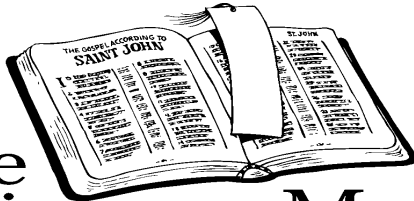

## Bible Readings for the Month

**May Scripture Readings:**

- 1<sup>st</sup> - **2 Kings 2:1-2, 6-14**  
 Steve **Psalm 77:1-2, 11-20 (UMH 798)**  
 Ropp **Galatians 5:1, 13-25**  
**Luke 9:51-62**
- 8<sup>th</sup> - **2 Kings 5:1-14**  
 Crystal **Psalm 30 (UMH 762)**  
 Armitage **Galatians 6: (1-6) 7-16**  
**Luke 10:1-11, 16-20**
- 15<sup>th</sup> - **Amos 7:7-17**  
 Stewart **Psalm 82 (UMH 804)**  
 King **Colossians 1:1-14**  
**Luke 10:25-37**
- 22<sup>nd</sup> - **Amos 8:1-12**  
 Liz **Psalm 52 or Psalm 82(UMH 804)**  
 Sanford **Colossians 1:15-28**  
**Luke 10:38-42**
- 29<sup>th</sup> - **Hosea 1:2-10**  
 5<sup>th</sup> **Psalm 85 (UMH 806)**  
 Sunday **Colossians 2:6-15 (16-19)**  
**Luke 11:1-13**

**Need a ride to Church???**

If anyone in the local area needs a ride to church on Sundays or to any church function or meeting, please call Judith Bartlett at 867-3002 or the church office at 867-3667 for help in making arrangements.

Also, if you are willing to give anyone a ride, please have your name put on the driver's list in the church office.

THANKS !!!

**Happy July Birthdays**

Gerald Ziehl	7/3	Norma Rissis	7/4
Brenda Ziehl	7/4	Mandy Robbins	7/10
Shawn McIntyre	7/11	Irma Maddern	7/12
Joseph Frazier	7/12	Oloose Mae Chicoine	7/14
Rev. Tom McKeon	7/15	Linda Robbins	7/18
Allan Reid	7/21	Dennis Bartlett	7/27
Mark Williamson	7/30		

**Celebrating Anniversaries in July**

Walter & Evelyn Hazen 7/?

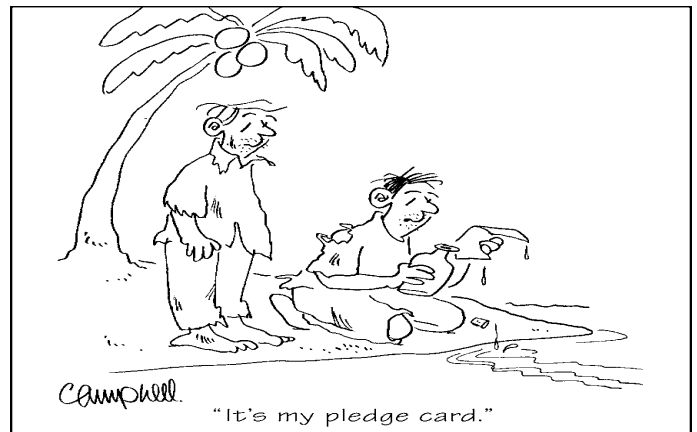
**The Grief and Loss Support Group**

**"YOU DON'T HAVE TO BE ALONE IN YOUR BE-REAVEMENT"**

The last Wednesday of each month at 1:00 P.M. Sponsored by the **WEST BROOKFIELD COUNCIL on AGING** at the Senior Center, 27 Front St. Everyone is welcome. For more information call Frank Halloran 867-2497.

**AN OPEN INVITATION**

The George Whitefield Rock welcomes any and all submissions. We reserve the right to edit or reject any material. This is your newsletter, please feel free to make any suggestions to the pastor or the editors. Also if you would like to share your loved ones birthdays and anniversaries please send them for submission to the editor.

Have you visited our web site lately?

[www.gbgm-umc.org/whitefield](http://www.gbgm-umc.org/whitefield)